

**River Restoration Toolbox  
Practice Guide 6**

Aquatic Habitat/Cover Features



Iowa Department of Natural  
Resources

April, 2018

## Table of Contents

<b>EXECUTIVE SUMMARY .....</b>	<b>1</b>
<b>1.0 INTRODUCTION .....</b>	<b>3</b>
<b>2.0 AQUATIC HABITAT/COVER FEATURE TECHNIQUES .....</b>	<b>3</b>
2.1 LUNKERS (BANKHIDES) .....	3
2.1.1 Narrative Description .....	3
2.1.2 Technique Information.....	4
2.1.3 Detail Drawings and Data Table .....	6
2.1.4 Specifications.....	10
2.1.5 Photographs.....	11
2.2 BOULDER/ROCK CLUSTERS.....	12
2.2.1 Narrative Description .....	12
2.2.2 Technique Information.....	12
2.2.3 Detail Drawings and Data Table .....	13
2.2.4 Specifications.....	17
2.2.5 Photographs.....	18
2.3 LOCKED LOGS.....	19
2.3.1 Narrative Description .....	19
2.3.2 Technique Information.....	19
2.3.3 Detail Drawings and Data Table .....	20
2.3.4 Specifications.....	24
2.3.5 Photographs.....	25
2.4 LARGE WOODY HABITAT .....	26
2.4.1 Narrative Description .....	26
2.4.2 Technique Information.....	26
2.4.3 Detail Drawings and Data Table .....	27
2.4.4 Specifications.....	31
2.4.5 Photographs.....	32
2.5 ROOT WADS.....	33
2.5.1 Narrative Description .....	33
2.5.2 Technique Information.....	33
2.5.3 Detail Drawings and Data Table .....	35
2.5.4 Specifications.....	39
2.5.5 Photographs.....	40
2.6 SUBMERGED CRIB WALL .....	41
2.6.1 Narrative Description .....	41
2.6.2 Technique Information.....	41
2.6.3 Detail Drawings and Data Table .....	41
2.6.4 Specifications.....	45
2.6.5 Photographs.....	46
<b>3.0 REFERENCES.....</b>	<b>47</b>

## RIVER RESTORATION TOOLBOX PRACTICE GUIDE 6

### LIST OF TABLES

Table 1. Required Design Data for LUNKERS <sup>1</sup> .....	6
Table 2. Required Design Data Boulder/Rock Clusters <sup>1</sup> .....	13
Table 3. Required Design Data for Locked Logs <sup>1</sup> .....	20
Table 4. Required Design Data for Large Woody Habitat <sup>1</sup> .....	27
Table 5. Required Design Data for Root Wads <sup>1</sup> .....	35
Table 6. Required Design Data for Submerged Crib Walls <sup>1</sup> .....	42

### LIST OF DRAWINGS

Drawing 1. LUNKERS.....	7
Drawing 2. Boulder/Rock Clusters .....	15
Drawing 3. Locked Logs .....	22
Drawing 4. Large Woody Habitat .....	28
Drawing 5. Root Wads .....	37
Drawing 6. Submerged Crib Wall.....	43

### LIST OF PHOTOGRAPHS

Photo 1. Constructed LUNKER structure. Source: Dave Derrick, 2013.....	11
Photo 2. Installed LUNKER structure. Source: Dave Derrick, 2013. ....	11
Photo 3. Boulder Cluster downstream of bridge. Source: Stantec.....	18
Photo 4. Boulder Cluster riffle. Source: Stantec.....	18
Photo 5. Constructed Locked Log structure. Source: Dave Derrick, 2013. ....	25
Photo 6. Locked Log structure during construction. Source: Dave Derrick, 2013. ....	25
Photo 7. Large Woody Habitat. Source: Stantec.....	32
Photo 8. Large Woody Habitat used to form riffle structure. Source: Stantec.....	32
Photo 9. Root Wad channel bank protection. Source: NRCS.....	40
Photo 10. Submerged Cribwall. Source: Unknown.....	46
Photo 11. Submerged Crib Wall. Source: Unknown. ....	46

### Executive Summary

Aquatic habitat and cover features provide in-stream diversity, complexity, and refugia for a variety of aquatic species. These features are critical to ensuring adequate in-stream habitat is provided throughout the year, and for a variety of in-stream flow conditions. These features are often used in conjunction with other forms of restoration, such as channel bank grading, and are selected based on site conditions, constraints, and specific project objectives. The following techniques are detailed in this report:

1. LUNKERS
2. Boulder/Rock Clusters
3. Locked Logs
4. Large Woody Habitat
5. Root Wads
6. Submerged Crib Wall

The *River Restoration Toolbox Practice Guide 6: Aquatic Habitat/Cover Features* has been developed to assist with the presentation of design and construction information for stream restoration in Iowa. It is intended to provide guidance to:

- Those responsible for reviewing and implementing stream restoration,
- Professionals responsible for the design of stream restoration projects,
- Others involved in stream restoration at various levels who may find the information useful as a technical reference to define and illustrate aquatic habitat and cover feature techniques.

The Practice Guide includes a written assessment of the aquatic habitat/cover features practice and describes a variety of aquatic habitat/cover techniques. Each technique includes design guidelines, a specifications list, photographs, and, when applicable, drawings.

**The information in the Practice Guide is intended to inform practitioners and others, and define typical information required by the State of Iowa to be included with the use of aquatic habitat/cover techniques. The information and drawings are not meant to represent a standard design method for any type of technique and shall not be used as such. The Practice Guide neither replaces the need for site-specific engineering and/or landscape designs, nor precludes the use of information not included herein.**

## **RIVER RESTORATION TOOLBOX PRACTICE GUIDE 6**

The Practice Guide may be updated and revised to reflect up-to-date engineering, science, and other information applicable to Iowa streams and rivers.

## RIVER RESTORATION TOOLBOX PRACTICE GUIDE 6

Introduction  
April, 2018

### 1.0 INTRODUCTION

Aquatic habitat/cover practices refer specifically to techniques whose primary purpose is to provide habitat for aquatic organisms. A variety of watershed impairments have resulted in the degradation of many streams leaving them lacking adequate habitat. A variety of aquatic habitat and cover features have been successfully designed and implemented into degraded streams in many locations, resulting in significant uplift. The restoration of aquatic habitat and cover features is critical to reestablishing macroinvertebrate communities, fish population, and a stable food web.

Stable streams with intact riparian areas and proper dimension, pattern and profile should provide adequate aquatic habitat for all organisms. When channels and/or riparian areas have been altered and destabilized aquatic habitat suffers. Unstable streams can lose crucial riffle and pool habitat along with low and high water refuge often resulting in unfavorable homogenous ecosystems.

Improving aquatic habitat requires identification of limiting factors. Different fish assemblages and life stages have diverse requirements for habitat and will respond differently to aquatic habitat improvements. Careful consideration should be given to the aquatic species present, what is limiting their populations, and what life stages are experiencing limiting factors before embarking on a project designed solely for the purpose of enhancing aquatic habitat. Projects that do not adequately determine these factors prior to design will not be successful.

The guidelines and specifications provided in this document are general and not a comprehensive design manual. It is the responsibility of the designer to understand the design approach and the feasibility of using different techniques on a case-by-case basis. The following criteria in no way replaces design discretion, experience, and training, and cannot incorporate every scenario. They are intended to flag common errors, promote empirically stable design ranges, assist designers and reviewers in communication, and adapt tested designs to Iowa conditions.

### 2.0 AQUATIC HABITAT/COVER FEATURE TECHNIQUES

#### 2.1 LUNKERS (BANKHIDES)

##### 2.1.1 Narrative Description

Fish LUNKERS (Little Underwater Neighborhood Keepers Encompassing Rheotactic Salmonids) are wooden structures installed along the bank to create overhead cover for fish (Vetrano 1988). LUNKERS were developed in Wisconsin for trout stream habitat improvement projects. Brown trout favor these structures; however, native brook trout will use the habitat in the absence of brown trout. Cavity spawners such as catfish should also benefit from LUNKERS during spawning

## RIVER RESTORATION TOOLBOX PRACTICE GUIDE 6

Aquatic Habitat/Cover Feature Techniques  
April, 2018

seasons and year-round during daylight hours when they prefer to hide under cover. Smallmouth bass have also been found to benefit from LUNKERS (Illinois State Water Survey 1992).

LUNKERS are beneficial for adding in-stream fish habitat in streams where it is challenging to add habitat by other, more natural, means. They are also useful for providing cover and shade along channel banks where riparian vegetation has been eliminated. LUNKERS can also be referred to as bankhides.

### 2.1.2 Technique Information

- **Use:** LUNKERS are primarily used to provide overhead cover for salmonids but have been used in Illinois for Smallmouth Bass and Catfish habitat (White et al. 2011).
- **Other uses:** Bank stability
- **Best applications:** LUNKERS work best when installed below the elevation of the low flow channel. LUNKERS depend on flow to maintain the undercut bank habitat. LUNKERS should not be built in unstable channels with high sediment supply or where current velocities are not adequate to keep the structure clear of sediment. This practice is rarely recommended for large streams with a greater than 15-20 square mile drainage area. LUNKERS work best in B, C and E type cold-water habitat streams.
- **Variations:**
  - Combining with bank shaping and/or multi-stage channels. See Floodplain Restoration Practice for more information.
  - Combining with stream bank stabilization (e.g. Rock Toe Protection, Toe Wood, etc.). See Streambank Toe Protection Practice for more information.
  - Design may vary based on availability of materials on site. More lumber may be incorporated in the design for driftless areas.
- **Computations:** Computations are generally not required for LUNKERS, with the exception of boulder sizing for use in securing the top of the structure or for the structure footing. LUNKERS require design by a professional.

Hydrologic and hydraulic computations aid in verifying that the appropriate conditions exist for use of these boulders. Geometric calculations are required to properly size and situate the structure within the context of its individual location. Hydraulic analysis is required to determine size, thickness, and/or depth of building materials that will resist becoming dislodged or undermined.

## RIVER RESTORATION TOOLBOX PRACTICE GUIDE 6

Aquatic Habitat/Cover Feature Techniques  
April, 2018

- **Key Features:**

- Dimensional lumber or natural logs are typically used to create the structure.
- Native or imported rock is used to secure the top of the structure, and use for the structure footing.
- Topsoil, native plantings, and erosion control blanket are used to stabilize the channel bank that was disturbed during the construction of the structure.

- **Cautions:**

- LUNKERS are prone to capturing sediment, and should be placed in locations within the stream to minimize sediment capture, such as on the outside of channel bends or in straight channel sections.
- Careful evaluation of the full range of flow stages is required to ensure that the structure remains submerged in water.
- LUNKERS need to be placed on a foundation that either resists scour or is buried to a depth below the anticipated scour level.



## RIVER RESTORATION TOOLBOX PRACTICE GUIDE 6

Aquatic Habitat/Cover Feature Techniques  
April, 2018

### 2.1.3 Detail Drawings and Data Table

The following drawings and data table depict information that should be included in construction plans for LUNKERS. The data table includes design guidelines and sources, where applicable.

<b>Dimension<sup>2</sup></b>	<b>Name</b>	<b>Typical Unit</b>	<b>Guidelines<sup>3</sup></b>	<b>Description</b>
A	Structure Width	Feet	Structure width should be designed such that the face of the structure meets the expected low flow water extents and extends approximately 3 feet into the channel bank.	Total width of the structure from the low flow channel bench into the channel bank.
B	Structure Length	Feet	Typical structure lengths is about 8 feet long.	Total length of the structure along the channel bank.
C	Log	Inches/ feet	12-18" Dia. X 3-8' long.	Log is buried into channel bank and locked into place with boulders and logs.
D	Anchor Rock	Feet	A D50 based on hydraulic and shear stress relationships at various discharges can conservatively be used as a minimum surface boulder size.	The surface boulders are intended to lock the wood material into place.
E	Structure Height	Feet	Structure is typically 1-2 feet tall.	Structure opening that in-stream species can enter.

1. Data are for LUNKERS.
2. Some dimension labels are referenced in the detail drawings.
3. Common guidance, values, or ranges are given unless they require computation using site-specific input.

# RIVER RESTORATION TOOLBOX PRACTICE GUIDE 6

Aquatic Habitat/Cover Feature Techniques  
April, 2018

## Drawing 1. LUNKERS

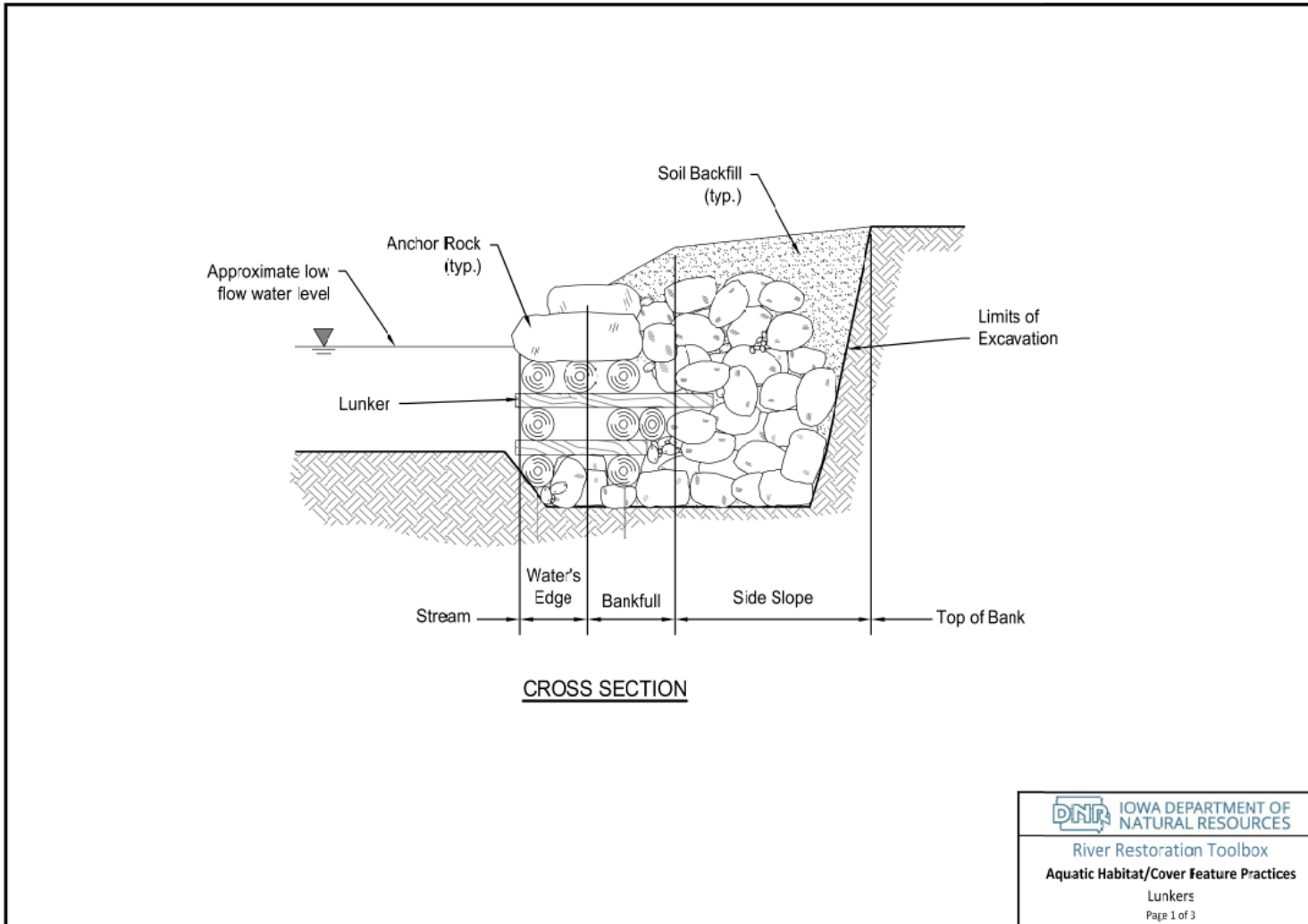

# RIVER RESTORATION TOOLBOX PRACTICE GUIDE 6

Aquatic Habitat/Cover Feature Techniques  
April, 2018

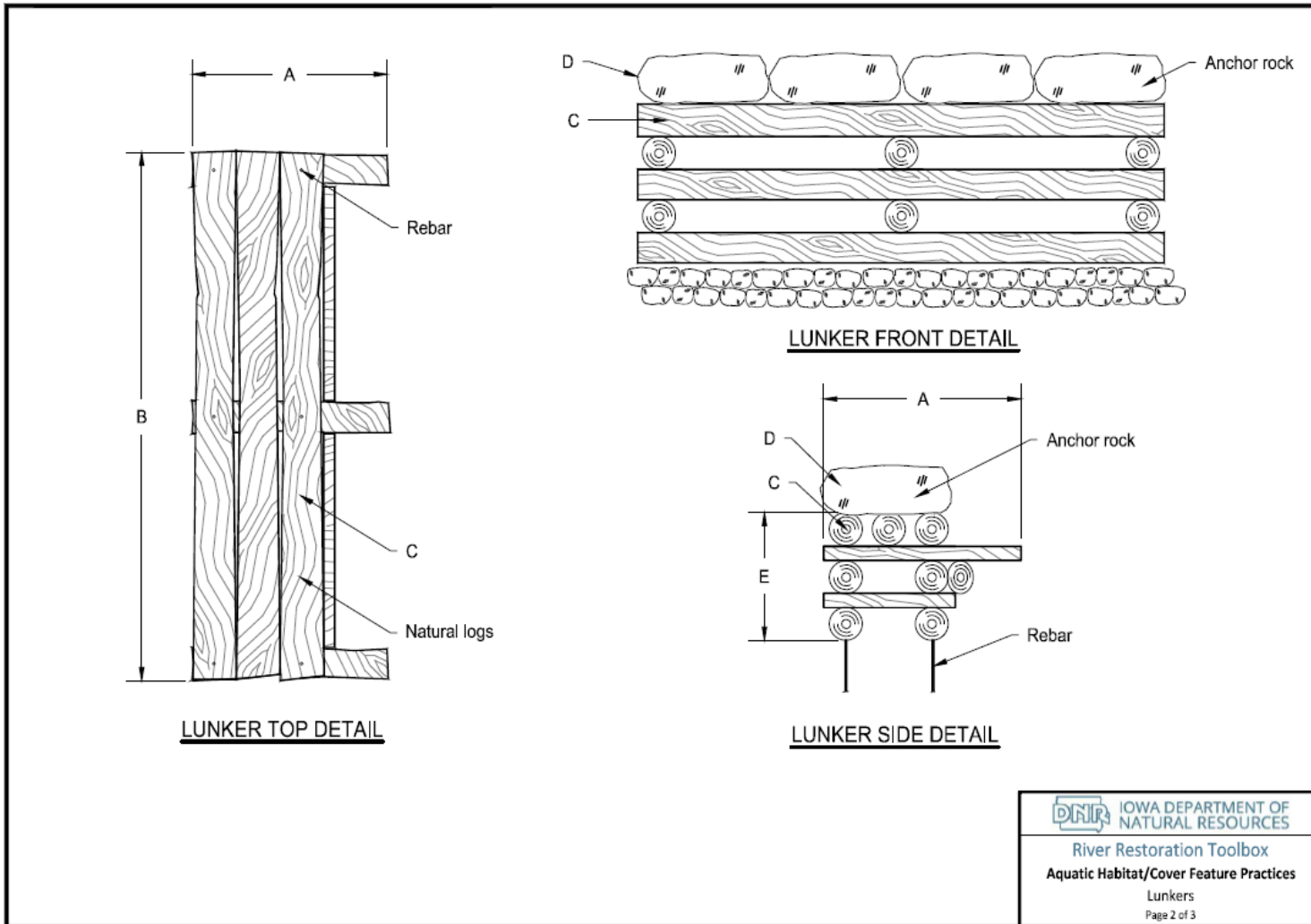

# RIVER RESTORATION TOOLBOX PRACTICE GUIDE 6

Aquatic Habitat/Cover Feature Techniques  
April, 2018

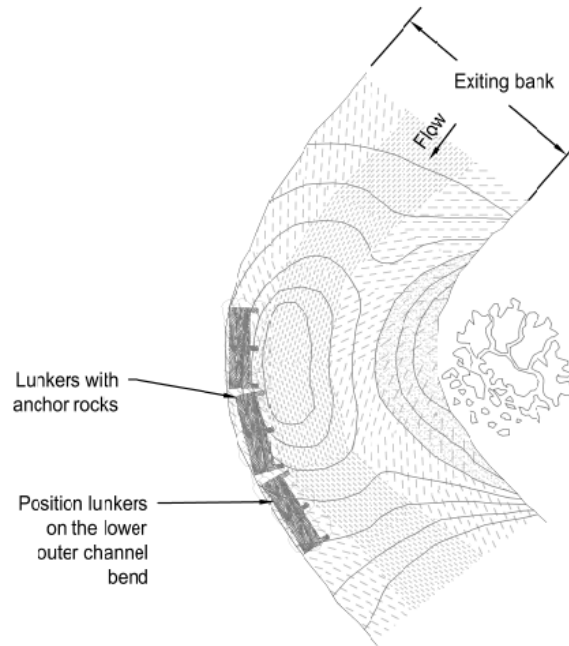

PLAN VIEW DETAIL

 IOWA DEPARTMENT OF NATURAL RESOURCES
River Restoration Toolbox
Aquatic Habitat/Cover Feature Practices
Lunkers
Page 3 of 3

Version 1.0 8/25/2017

## RIVER RESTORATION TOOLBOX PRACTICE GUIDE 6

Aquatic Habitat/Cover Feature Techniques  
April, 2018

### 2.1.4 Specifications

The following information should be developed into specifications to accompany the use LUNKERS:

- Materials:
  - Untreated wood
  - Stone
- Equipment/Tools:
  - Shovels
  - Pry bars
  - Picks
  - Chain saw
  - Excavator with thumb attached or backhoe for placement
- Sequence:
  - Establish relevant elevations
  - Build spacers
  - Form LUNKER bottom
  - Form LUNKER top
  - Prepare for placement
- Workmanship: It's optimal to install LUNKERS during low flow conditions to ensure the structures remain underwater.
- Maintenance: A scheduled monitoring and maintenance program is recommended in order to remove debris and or sediment that has accumulated in or near the structure.

## RIVER RESTORATION TOOLBOX PRACTICE GUIDE 6

Aquatic Habitat/Cover Feature Techniques  
April, 2018

### 2.1.5 Photographs



**Photo 1.** Constructed LUNKER structure. Source: Dave Derrick, 2013.



**Photo 2.** Installed LUNKER structure. Source: Dave Derrick, 2013.

## 2.2 BOULDER/ROCK CLUSTERS

### 2.2.1 Narrative Description

Boulder/rock clusters are sets of large stones placed in the stream channel to provide fish habitat. Scour around stones create current refugia for fish, and disturbance of the water surface provides overhead cover. The current break created behind boulder/rock cluster can also be used during the spawning season for multiple species of fish.

### 2.2.2 Technique Information

- **Use:** Boulder/rock clusters are used in newly constructed restoration projects to mimic natural rock features.
- **Other uses:** Boulder/rock clusters provide habitat diversity.
- **Best applications:** Place boulders so current will not be deflected into unprotected stream banks. Boulder/rock clusters should be placed in or near the thalweg of stable stream reaches (Fischenich and Seal 2000). Not recommended for use in sand bed streams. Boulder/rock clusters will work best in B or C channel types with cobble or gravel substrate. Boulder/rock clusters will be needed in newly constructed boulder channels but should not be a limiting factor in natural boulder channels.
- **Variations:** Boulder/rock clusters can be embedded into rock riffles to add riffle complexity, habitat, and provide refugia for fish. Cluster placement can deviate from the detail below. A random boulder pattern is effective at creating desired habitat diversity.
- **Computations:** Computations are necessary to properly size rock material and should accompany any design using boulder/ rock clusters. Boulder/rock clusters require design by a professional.

Hydrologic and hydraulic computations aid in verifying that the appropriate conditions exist for use of boulder/rock clusters. Geometric calculations are required to properly size and situate the structure within the context of its individual location. Hydraulic analysis is required to determine size, thickness, and/or depth of building materials that will resist becoming dislodged or undermined.

- **Key Features:** Boulders and/or large diameter rock.
- **Cautions:** Boulders and/or rock should be property embedded into the channel bottom and/or the channel bank to reduce the risk of unintended localized scour and mobilization.

## RIVER RESTORATION TOOLBOX PRACTICE GUIDE 6

Aquatic Habitat/Cover Feature Techniques  
 April, 2018

### 2.2.3 Detail Drawings and Data Table

The following drawings and data table depict information that should be included in construction plans for boulder/rock clusters. The data table includes design guidelines and sources, where applicable.

**Table 2. Required Design Data Boulder/Rock Clusters<sup>1</sup>**

Dimension <sup>2</sup>	Name	Typical Unit	Guidelines <sup>3</sup>	Description
A	Boulder protrusion	Feet	0.5 ft. – to maximum ½ boulder thickness. Generally, less protrusion toward the center of channel and more protrusion the boulders reach the banks is advisable.	Distance that weir boulders protrude out of the base stone layer.
B	Boulder burial	Feet	0.5 ft. – to maximum ½ boulder thickness. Generally, more burial depth toward the center of channel and less as the boulders reach the banks is advisable.	Depth that boulders are embedded into channel alluvium.
C	Boulder length	Feet	3.5 ft. average; ideally boulders should be longer than they are wide and thick ("flat-shaped"), to resist rotation, tumbling, and be of a durable composition. They should be large enough to resist movement due to shear stress generated by concentrated flow (including ice and debris).	One of three measurements to describe size of weir boulder building materials, the length is typically the largest dimension.



## RIVER RESTORATION TOOLBOX PRACTICE GUIDE 6

Aquatic Habitat/Cover Feature Techniques  
 April, 2018

**Table 2. Required Design Data Boulder/Rock Clusters<sup>1</sup>**

Dimension <sup>2</sup>	Name	Typical Unit	Guidelines <sup>3</sup>	Description
D	Boulder width	Feet	3.0 ft average; ideally boulders should be longer than they are wide and thick ("flat-shaped"), to resist rotation, tumbling, and be of a durable composition. They should be large enough to resist movement due to shear stress generated by concentrated flow (including ice and debris).	One of three measurements to describe size of weir boulder building materials, the width is typically the median dimension.
E	Boulder thickness	Feet	1.8 ft minimum; ideally boulders should be longer than they are wide and thick ("flat-shaped"), to resist rotation, tumbling, and be of a durable composition. They should be large enough to resist movement due to shear stress generated by concentrated flow (including ice and debris).	One of three measurements to describe size of weir boulder building materials, the thickness is typically the smallest dimension.

1. Data are for boulder/rock clusters.
2. Some dimension labels are referenced in the detail drawings.
3. Common guidance, values, or ranges are given unless they require computation using site-specific input.

# RIVER RESTORATION TOOLBOX PRACTICE GUIDE 6

Aquatic Habitat/Cover Feature Techniques  
April, 2018

## Drawing 2. Boulder/Rock Clusters

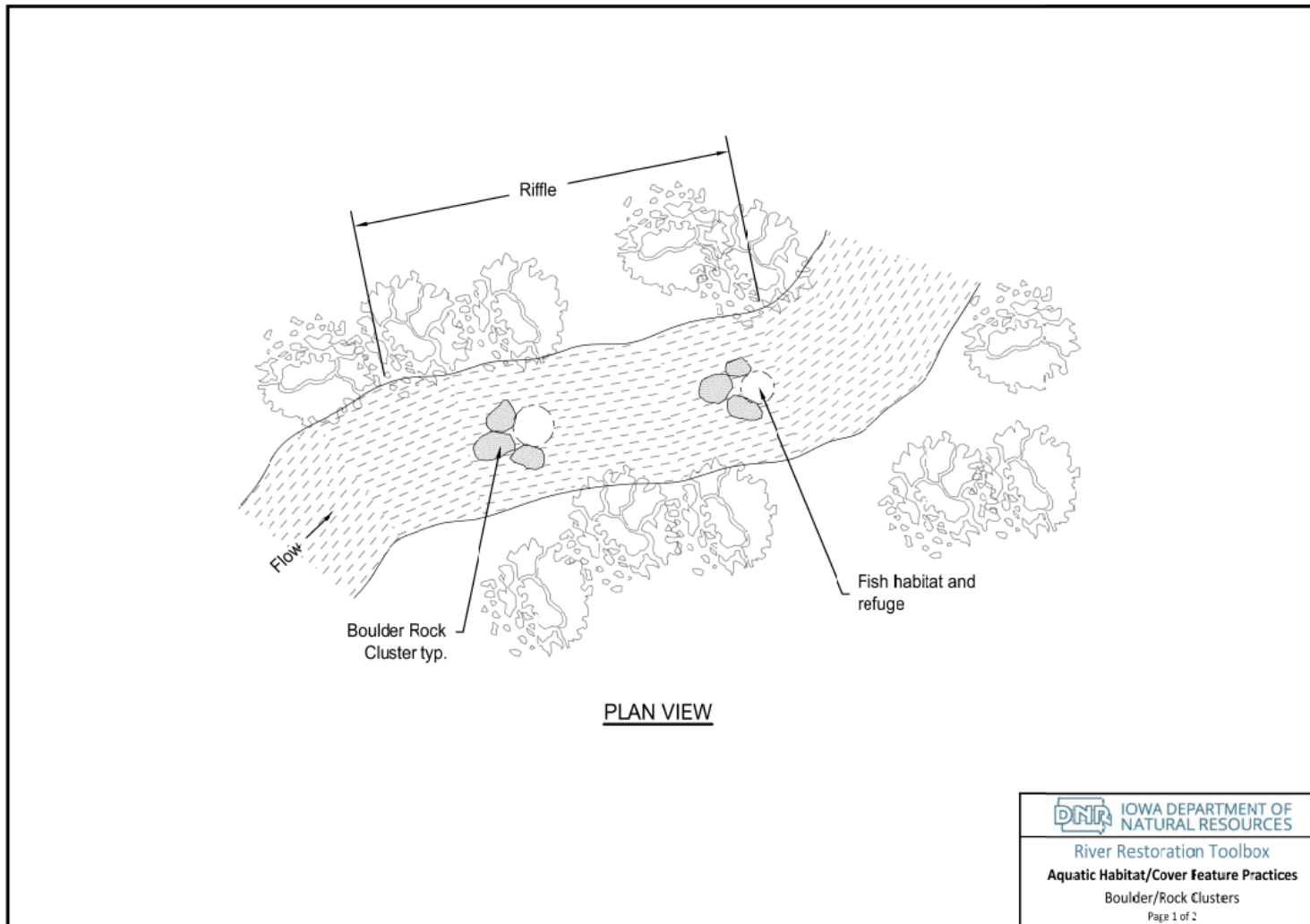

# RIVER RESTORATION TOOLBOX PRACTICE GUIDE 6

Aquatic Habitat/Cover Feature Techniques  
April, 2018

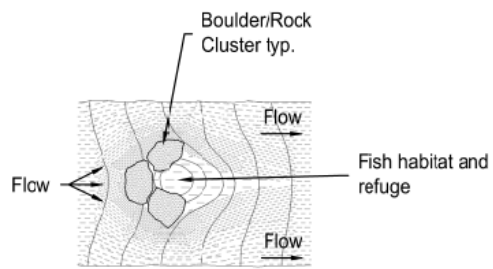

BOULDER/ROCK CLUSTER DETAIL

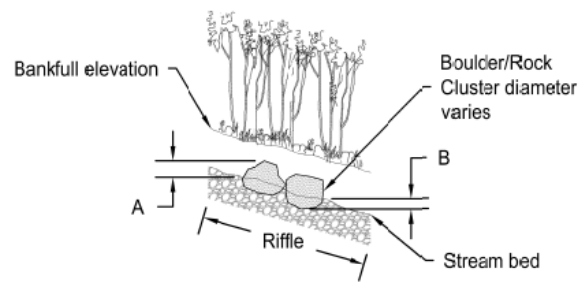

PROFILE VIEW

 IOWA DEPARTMENT OF NATURAL RESOURCES
River Restoration Toolbox
Aquatic Habitat/Cover Feature Practices
Boulder/Rock Clusters
Page 2 of 2

Version 1.0 8/25/2017

## RIVER RESTORATION TOOLBOX PRACTICE GUIDE 6

Aquatic Habitat/Cover Feature Techniques  
April, 2018

### 2.2.4 Specifications

- Materials: Boulders
- Equipment/Tools: Excavator with a thumb attachment
- Sequence:
  - Excavate the portion of the channel bottom and/or channel bank where the boulder will be placed.
  - Place the boulder in the excavated hole.
  - Backfill around the boulder with native alluvium and/or channel bank material.
- Workmanship: Stones should be purposefully placed into the stream, never dumped in. Stones should be embedded into the channel bottom.
- Maintenance: Boulder/rock clusters require minimal maintenance; however, they should be inspected annually for movement that may be indicative stability issues.

## RIVER RESTORATION TOOLBOX PRACTICE GUIDE 6

Aquatic Habitat/Cover Feature Techniques  
April, 2018

### 2.2.5 Photographs



**Photo 3.** Boulder Cluster downstream of bridge. Source: Stantec



**Photo 4.** Boulder Cluster riffle. Source: Stantec

## RIVER RESTORATION TOOLBOX PRACTICE GUIDE 6

Aquatic Habitat/Cover Feature Techniques  
April, 2018

### 2.3 LOCKED LOGS

#### 2.3.1 Narrative Description

Locked logs are woody habitat anchored into place below the water surface with stones. Lock logs consists of entire tree, limbs, tree tops, etc. anchored within or placed under structures, with limbs/logs protruding into deeper scoured areas to provide in-stream cover, vertical and horizontal structure, hydraulic roughness, & areas of refugia (Derrick 2013).

#### 2.3.2 Technique Information

- **Use:** Locked logs are used on channel margins to create in-stream habitat.
- **Other uses:** None.
- **Best applications:** Place locked logs under water and angled in the downstream direction by 15-35 degrees, and protruding into deeper scoured areas. Stone is placed on top of the logs to secure them into place.
- **Variations:**
  - Combining with bank shaping and/or multi-stage channels. See Floodplain Restoration Practice for more information.
  - Combining with stream bank stabilization (e.g. Rock Toe Protection, Toe Wood, etc.). See Streambank Toe Protection Practice for more information.
- **Computations:** Computations are necessary and should accompany any design using rock and/or boulders. Locked logs require design by a professional. Hydrologic and hydraulic computations aid in verifying that the appropriate conditions exist for use of locked logs.
- **Key Features:** Trees, limbs, tree tops, root wads, and rock.
- **Cautions:**
  - Locked logs should be placed in lower energy locations, such as pools.
  - Woody material must be secured with rock anchors.
  - Woody material must be placed so that it is angled in the downstream direction to avoid becoming dislodged.
  - Note that this technique differs from Section 2.5 Root Wads in that the root wads are positioned such that the root wad portion is buried into the adjacent bank with the trunk pointing into the channel.

## RIVER RESTORATION TOOLBOX PRACTICE GUIDE 6

Aquatic Habitat/Cover Feature Techniques  
 April, 2018

### 2.3.3 Detail Drawings and Data Table

The following drawings and data table depict information that should be included in construction plans for locked logs. The data table includes design guidelines and sources, where applicable.

**Table 3. Required Design Data for Locked Logs<sup>1</sup>**

Dimension <sup>2</sup>	Name	Typical Unit	Guidelines <sup>3</sup>	Description
A	Log vane angle	Degrees	15-35°; measured upstream from the tangent line where the log vane intercepts the bank. Angle variation is used to adjust log vane length to accommodate the size of logs available.	The angle between the log vane and the stream bank.
B	Bankfull width (W <sub>bkf</sub> )	Feet	Small to large streams.	The channel width at bankfull stage, where discharge has filled the channel to the top of its banks and water begins to overflow onto a floodplain.
C	Rock/Boulder Backfill	Feet	A D50 based on hydraulic and shear stress relationships at various discharges can conservatively be used as a minimum stone size. Voids can be filled with chokestone to help base stone resist movement.	This layer of material is intended to lock the wood material into place.
D	Log with Root Wad	Inches	12-18" Dia. X 24-30' long, with root ball intact.	Root ball is buried into channel bank and placed on top of other woody material to lock it into place within the channel.

## RIVER RESTORATION TOOLBOX PRACTICE GUIDE 6

Aquatic Habitat/Cover Feature Techniques  
April, 2018

**Table 3. Required Design Data for Locked Logs<sup>1</sup>**

<b>Dimension<sup>2</sup></b>	<b>Name</b>	<b>Typical Unit</b>	<b>Guidelines<sup>3</sup></b>	<b>Description</b>
E	Foundation Log	Inches/feet	12-18" Dia. X 24-30' long	Used as a footer log for the root wad.

1. Data are for locked logs.
2. Some dimension labels are referenced in the detail drawings.
3. Common guidance, values, or ranges are given unless they require computation using site-specific input.



# RIVER RESTORATION TOOLBOX PRACTICE GUIDE 6

Aquatic Habitat/Cover Feature Techniques  
April, 2018

## Drawing 3. Locked Logs

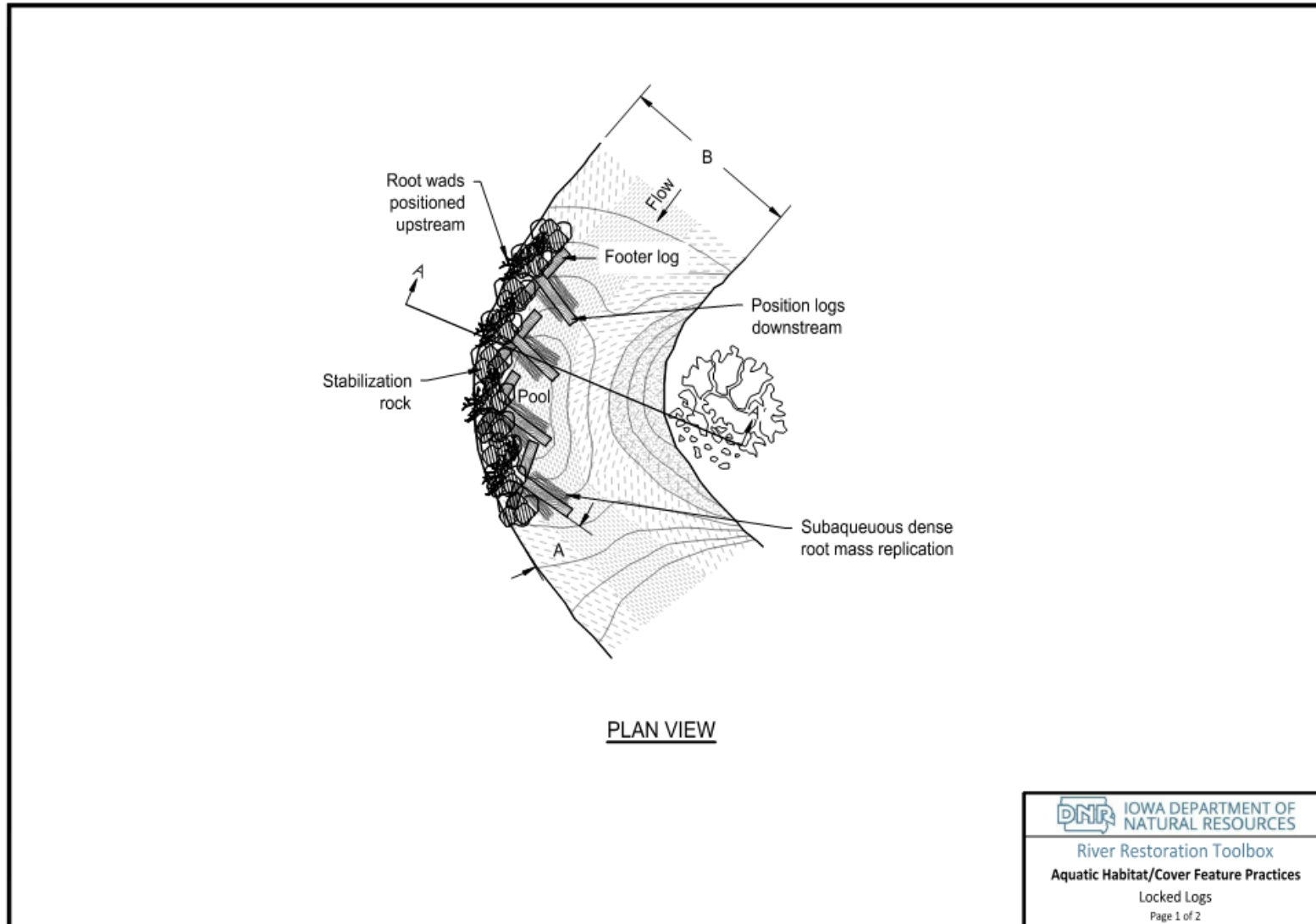

# RIVER RESTORATION TOOLBOX PRACTICE GUIDE 6

Aquatic Habitat/Cover Feature Techniques  
April, 2018

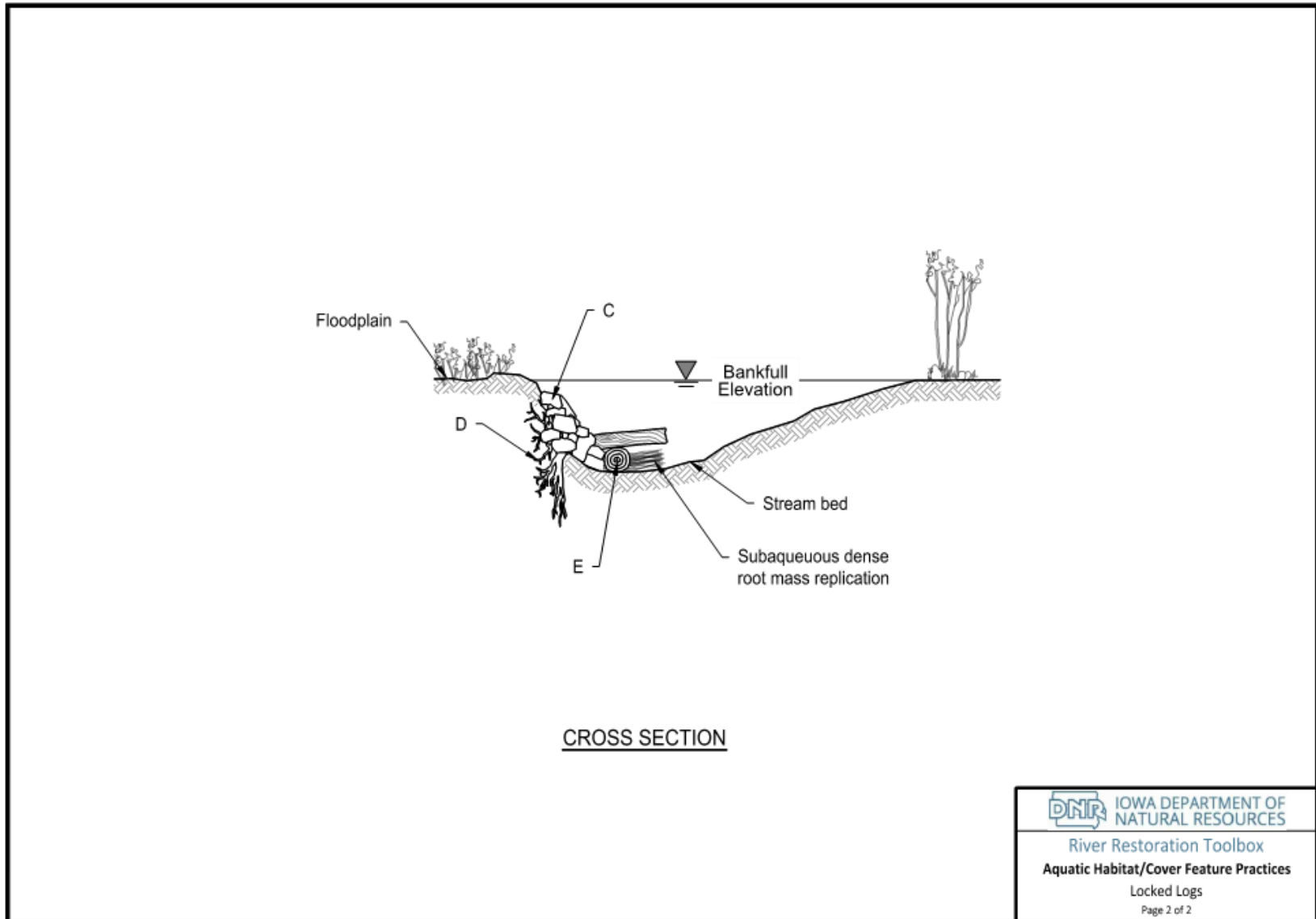

Version 1.0 8/25/2017

## RIVER RESTORATION TOOLBOX PRACTICE GUIDE 6

Aquatic Habitat/Cover Feature Techniques  
April, 2018

### 2.3.4 Specifications

- Materials: Trees, limbs, root wads, tree tops, and rock.
- Equipment/Tools: Excavator with a thumb attachment
- Sequence:
  - Place trees, limbs, branches, etc. on the bed of the stream.
  - Angle all wood material in the downstream direction at the appropriate angle (refer to reference conditions).
  - Place stone on the wood material.
- Workmanship: Logs should be angled 15-35 degrees relative to the bank downstream
- Maintenance: Locked logs should be inspected after major flow events to ensure wood material has not mobilized and/or caused unexpected scour.

## RIVER RESTORATION TOOLBOX PRACTICE GUIDE 6

Aquatic Habitat/Cover Feature Techniques  
April, 2018

### 2.3.5 Photographs



**Photo 5.** Constructed Locked Log structure. Source: Dave Derrick, 2013.



**Photo 6.** Locked Log structure during construction. Source: Dave Derrick, 2013.

### 2.4 LARGE WOODY HABITAT

#### 2.4.1 Narrative Description

Woody habitat is important cover for many species of fish. Historic and current land use practices have degraded and replaced forested riparian areas with farmland, manicured lawns, and urban infrastructure thereby removing the natural process of wood recruitment into streams. Woody habitat provides cover for a variety aquatic organisms including: fish, invertebrates, mammals, and reptiles.

Maintaining natural recruitment of woody habitat into streams can be accomplished through riparian management, protecting forested riparian buffers will allow natural contributions of woody habitat to occur without intervention. Refer to River Restoration Toolbox Practice Guide 3: Riparian Buffers for more information on forested riparian buffers.

#### 2.4.2 Technique Information

- **Use:** Woody habitat is used in streams where natural wood recruitment is limited, habitat is poor, or newly constructed channels to mimic natural features.
- **Other uses:** Large wood can be used to disperse flow energy, cause localized deposition, and is a source of organic matter.
- **Best applications:** Large woody habitat is best used in B, C, E, and F channels. Woody habitat can be placed in either riffle or pool locations depending on stream type (Rosgen 1996).
- **Computations:** Computations are necessary and should accompany any design using Large Woody Habitat. Large Woody Habitat requires design by a professional. Hydrologic and hydraulic computations aid in verifying that the appropriate conditions exist for use of Large Woody Habitat. Geometric calculations are required to properly size and situate the structure within the context of its individual location. Hydraulic analysis is required to determine the appropriate rock size that will resist becoming dislodged or undermined.
- **Key Features:** Logs and boulders
- **Cautions:**
  - Woody material must be secured with rock anchors to prevent flotation.
  - It should be noted that variations in wood density and rot resistance make some species of trees better choices for longevity of the project.

**RIVER RESTORATION TOOLBOX PRACTICE GUIDE 6**

Aquatic Habitat/Cover Feature Techniques  
 April, 2018

**2.4.3 Detail Drawings and Data Table**

The following drawings and data table depict information that should be included in construction plans for large woody habitat. The data table includes design guidelines and sources, where applicable.

**Table 4. Required Design Data for Large Woody Habitat<sup>1</sup>**

Dimension <sup>2</sup>	Name	Typical Unit	Guidelines <sup>3</sup>	Description
A	Low flow channel width	Feet	Small to large streams.	The channel width at low flow stage, where discharge has filled the inner berm.
B	Bankfull width (W <sub>bkf</sub> )	Feet	Small to large streams.	The channel width at bankfull stage, where discharge has filled the channel to the top of its banks and water begins to overflow onto a floodplain.
C	Surface Boulder	Feet	A D50 based on hydraulic and shear stress relationships at various discharges can conservatively be used as a minimum surface boulder size.	The surface boulders are intended to lock the wood material into place.
D	Log	Inches/feet	12-18" Dia. X length appropriate to span channel and be keyed into channel bank.	Log is buried into channel bank and locked into place with surface boulders.

1. Data are for large woody habitat.
2. Some dimension labels are referenced in the detail drawings.
3. Common guidance, values, or ranges are given unless they require computation using site-specific input.

# RIVER RESTORATION TOOLBOX PRACTICE GUIDE 6

Aquatic Habitat/Cover Feature Techniques  
April, 2018

## Drawing 4. Large Woody Habitat

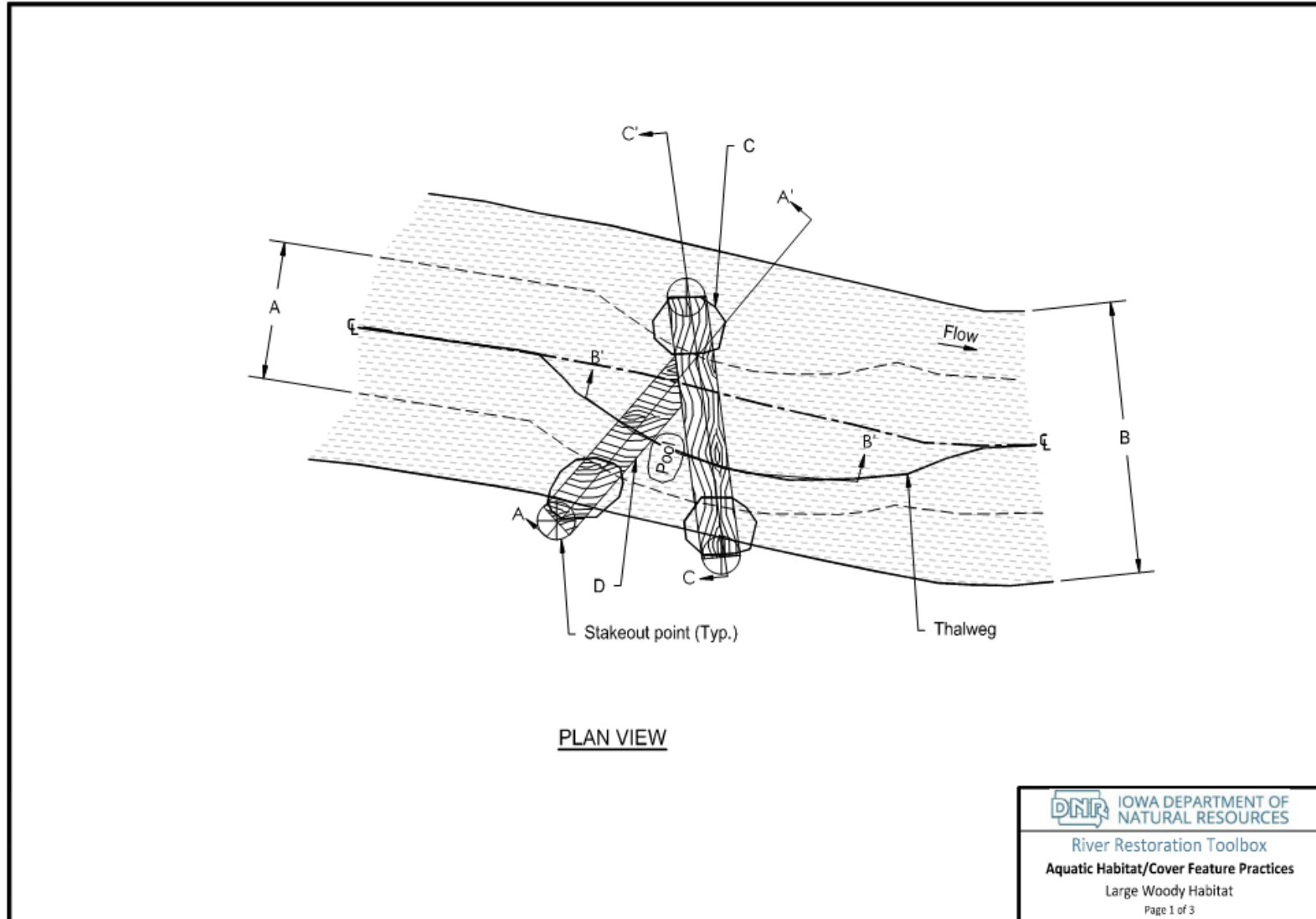

# RIVER RESTORATION TOOLBOX PRACTICE GUIDE 6

Aquatic Habitat/Cover Feature Techniques  
April, 2018

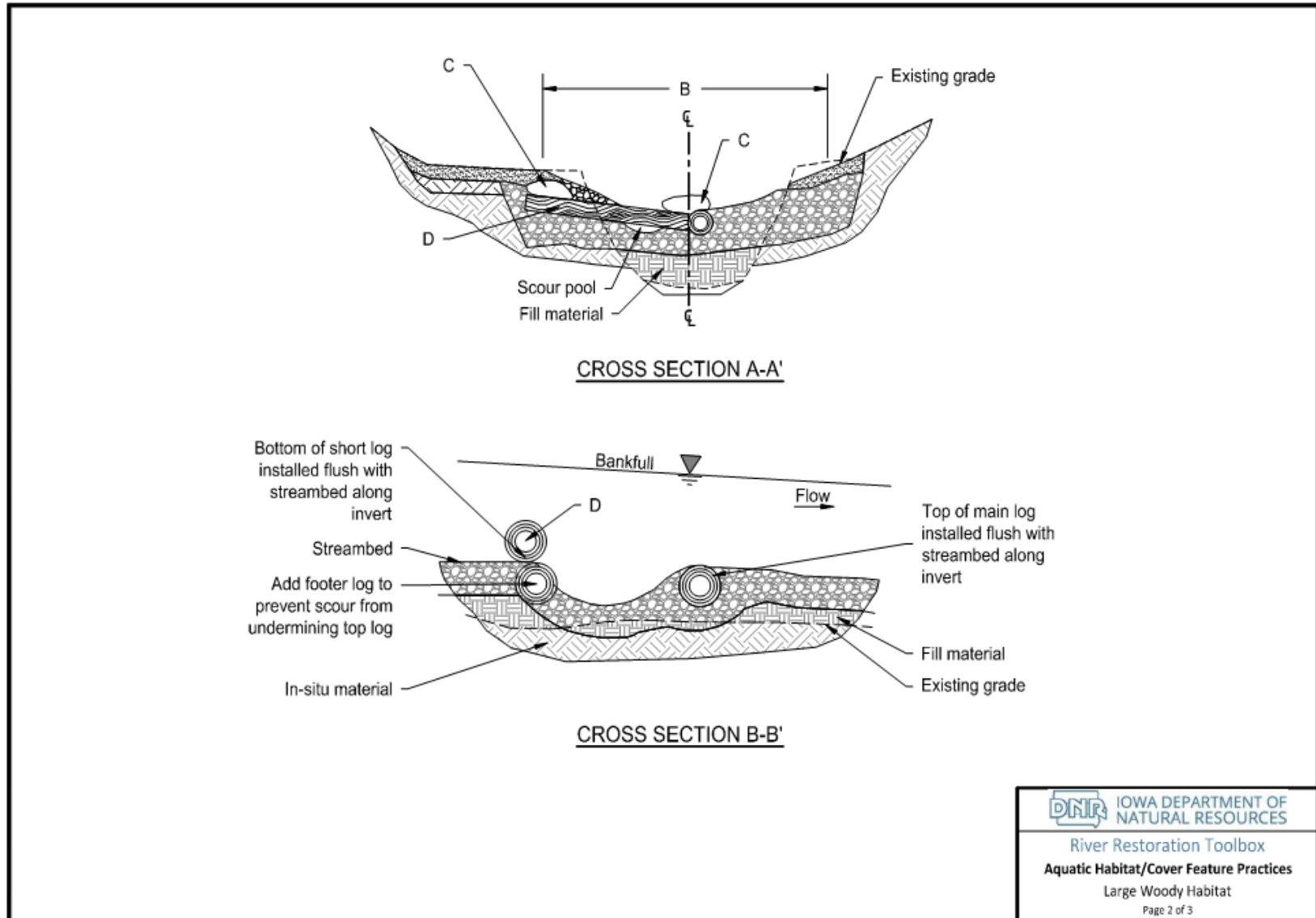

Version 1.0 8/25/2017



# RIVER RESTORATION TOOLBOX PRACTICE GUIDE 6

Aquatic Habitat/Cover Feature Techniques  
April, 2018

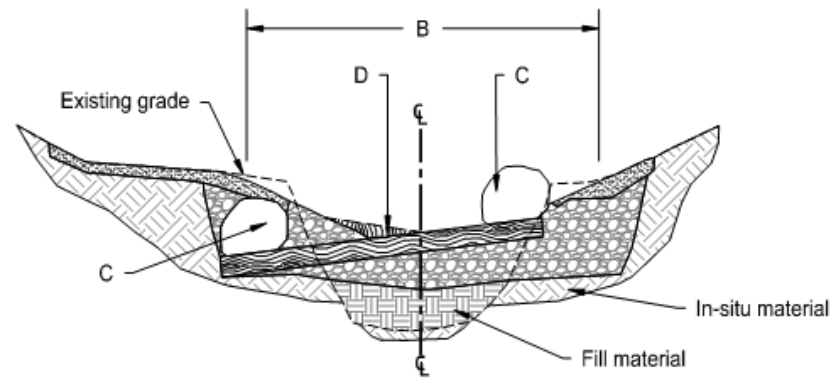

CROSS SECTION C-C'

	IOWA DEPARTMENT OF NATURAL RESOURCES
River Restoration Toolbox	
Aquatic Habitat/Cover Feature Practices	
Large Woody Habitat	
Page 3 of 3	

Version 1.0 8/25/2017

## RIVER RESTORATION TOOLBOX PRACTICE GUIDE 6

Aquatic Habitat/Cover Feature Techniques  
April, 2018

### 2.4.4 Specifications

- Materials:
  - Large woody habitat can consist of entire trees or large branches
  - Anchoring system
    - Cables, etc.
    - Boulders
- Equipment/Tools: excavator with thumb attachment
- Sequence:
  - Place footer log flush with channel invert, either by way of excavation or fill
  - Secure footer log by placing boulders on ends of footer log
  - Place surface log on top of footer log
  - Secure surface log by placing boulders on ends of log
- Workmanship: Dry wood floats, suitable anchoring methods are necessary to keep woody habitat in place. Improperly placed or anchored wood can cause more harm than good. Bank erosion, large log jams, or culvert plugging can result when woody habitat is improperly designed.
- Maintenance: Locked logs should be inspected after major flow events to ensure wood material has not mobilized and/or caused unexpected scour.

## RIVER RESTORATION TOOLBOX PRACTICE GUIDE 6

Aquatic Habitat/Cover Feature Techniques  
April, 2018

### 2.4.5 Photographs



**Photo 7.** Large Woody Habitat. Source: Stantec.



**Photo 8.** Large Woody Habitat used to form riffle structure. Source: Stantec.

## RIVER RESTORATION TOOLBOX PRACTICE GUIDE 6

Aquatic Habitat/Cover Feature Techniques  
April, 2018

### 2.5 ROOT WADS

#### 2.5.1 Narrative Description

Root wads include the root mass of a tree and are used to enhance aquatic habitat. The complexity of root wads provide ideal habitat for fish in the form of cover and current refugia.

#### 2.5.2 Technique Information

- **Use:** Individual root wads can be used as habitat enhancements in pools or low gradient riffles. Logs are placed parallel to flow with the root wad facing upstream and anchored into place with boulders.
- **Other uses:** Root wads used in toe wood provide habitat and bank stabilization, see River Restoration Toolbox Practice Guide 7: Stream Bank Toe Protection/Stabilization for more information on toe wood.
- **Best applications:** Root wad habitat are best used in newly constructed channels to mimic habitat of natural channels and in streams where woody habitat is limited. Root wads are best used in B, C, E, and F channels and can be placed in either riffle or pool locations depending on stream type (Rosgen 1996). Root wads should be stockpiled during grubbing operations of a stream restoration project.
- **Computations:** Hydrologic and hydraulic computations aid in verifying that the appropriate conditions exist for use of a root wad of a given size. Hydraulic analysis is required to determine the if the root wad is properly anchored, and can resist the expected stream forces. Buoyancy calculations should also be performed to ensure the root wad does not become buoyant and float away during the expected stream flows. Root wads require design by a professional
- **Key Features:**
  - The surface log that consists of a downed tree with the root ball intact. The tree trunk is buried in the channel bank such that the root wad is angled slightly in the upstream direction.
  - A footer log that the surface log rests on.
  - Anchor boulders that are placed upstream, downstream, and on top of the log to lock it into place.

## RIVER RESTORATION TOOLBOX PRACTICE GUIDE 6

Aquatic Habitat/Cover Feature Techniques  
April, 2018

- **Cautions:**

- Root wads should be installed continuously along the channel bank such that no gaps exist between the root balls. Any gaps in root mass could result in undesirable channel bank erosion.
- The upstream and downstream extents of the root wad bank protection should be anchored back into the channel bank with either additional root wads, or boulders, to prevent channel bank erosion.
- The orientation of the log/root should be placed parallel to valley walls and oriented upstream so that flood flows push root wads into the bank rather than pull away from the bank under flow.

**RIVER RESTORATION TOOLBOX PRACTICE GUIDE 6**

Aquatic Habitat/Cover Feature Techniques  
 April, 2018

**2.5.3 Detail Drawings and Data Table**

The following drawings and data table depict information that should be included in construction plans for root wads. The data table includes design guidelines and sources, where applicable.

**Table 5. Required Design Data for Root Wads<sup>1</sup>**

Dimension <sup>2</sup>	Name	Typical Unit	Guidelines <sup>3</sup>	Description
A	Log vane angle	Degrees	35-55°; measured upstream from the tangent line where the log vane intercepts the bank. Angle variation is used to adjust log vane length to accommodate the size of logs available.	The angle between the log vane and the stream bank.
B	Tree limbs, branches, etc.	Inches/Feet	Tree limbs, branches, etc. that are no larger than 2 inches in diameter. Length should be such that slash material can be buried into the channel bank at least ½ the length of the root wad and not protrude into the bankfull channel more than 1/3 of the bankfull width.	Slash material placed on top of root wads.
C	Bankfull width (W <sub>bkf</sub> )	Feet	Small to large streams.	The channel width at bankfull stage, where discharge has filled the channel to the top of its banks and water begins to overflow onto a floodplain.

## RIVER RESTORATION TOOLBOX PRACTICE GUIDE 6

Aquatic Habitat/Cover Feature Techniques  
April, 2018

**Table 5. Required Design Data for Root Wads<sup>1</sup>**

Dimension <sup>2</sup>	Name	Typical Unit	Guidelines <sup>3</sup>	Description
D	Root Wad Submergence	Inches	½ of root fan diameter.	Root wads should be placed such that ½ of the root fan diameter is submerged during low-flow conditions.
E	Root Wad	Inches/feet	12-18" Dia. X 24-30' long, with root ball intact.	Root ball is buried into channel bank with the root fan protruding into the bankfull channel and facing slightly upstream.
F	Foundation Log	Inches/Feet	12-18" Dia. X 24-30' long.	Used as a footer log for the root wad.

1. Data are for root wads.
2. Some dimension labels are referenced in the detail drawings.
3. Common guidance, values, or ranges are given unless they require computation using site-specific input.

# RIVER RESTORATION TOOLBOX PRACTICE GUIDE 6

Aquatic Habitat/Cover Feature Techniques  
April, 2018

## Drawing 5. Root Wads

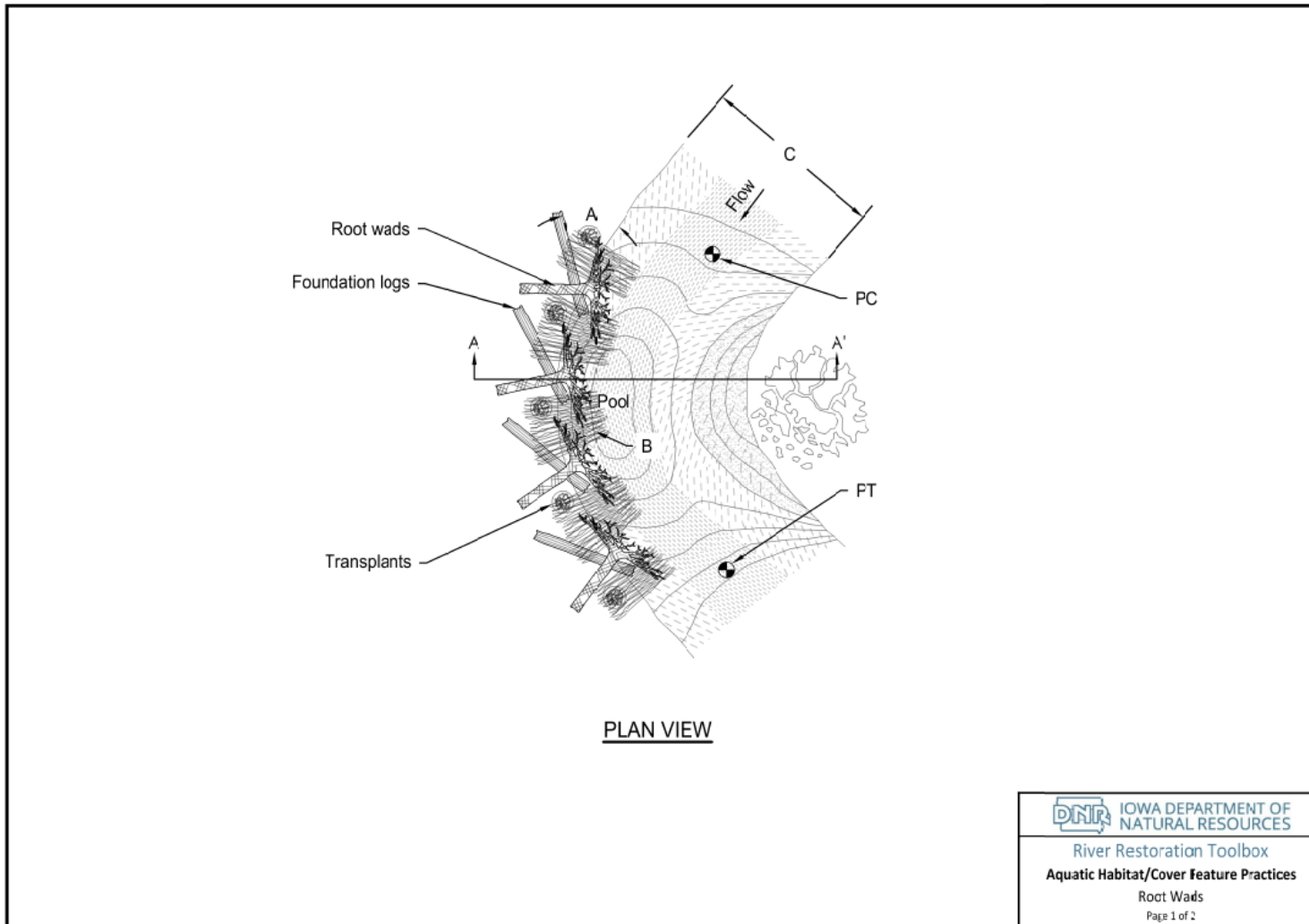



# RIVER RESTORATION TOOLBOX PRACTICE GUIDE 6

Aquatic Habitat/Cover Feature Techniques  
April, 2018

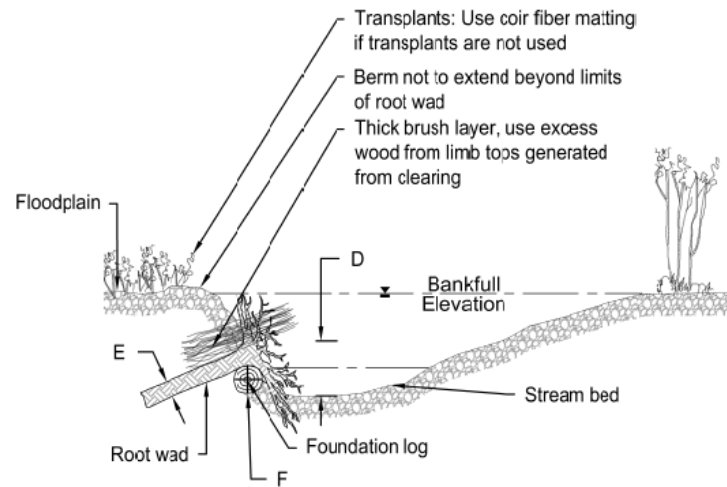

CROSS SECTION

**DNR** IOWA DEPARTMENT OF NATURAL RESOURCES

River Restoration Toolbox  
Aquatic Habitat/Cover Feature Practices

Root Wads

Page 2 of 2

Version 1.0 8/25/2017

## RIVER RESTORATION TOOLBOX PRACTICE GUIDE 6

Aquatic Habitat/Cover Feature Techniques  
April, 2018

### 2.5.4 Specifications

- Materials:
  - Trees with root ball intact
  - Boulders
- Equipment: Excavator with a thumb attachment
- Sequence:
  - Excavate channel bank
  - Place footer log in the bottom of the excavation such that it is angled away from the channel bank by 20-30 degrees.
  - Place surface log on top of footer log, slightly angles in the upstream direction.
  - Lock the surface log into place with boulders placed on top of the surface log and at the upstream and downstream interface with the channel bank.
  - Place tree limbs and branches on top of the surface log and backfill over both with native channel bank material.
- Workmanship:
  - Relatively fresh and un-rotted trees should be used.
  - Root wads should be placed continuously along the channel bank, and anchored back into the channel bank where the bank treatment ends.
  - Root wads should be submerged such that one-half of the root ball diameter is submerged during low flow conditions.
- Maintenance: Root wads should be inspected after major flow events during the revegetation period to ensure unexpected channel bank erosion has not occurred.

## RIVER RESTORATION TOOLBOX PRACTICE GUIDE 6

Aquatic Habitat/Cover Feature Techniques  
April, 2018

### 2.5.5 Photographs



**Photo 9.** Root Wad channel bank protection. Source: NRCS.

## RIVER RESTORATION TOOLBOX PRACTICE GUIDE 6

Aquatic Habitat/Cover Feature Techniques  
April, 2018

### 2.6 SUBMERGED CRIB WALL

#### 2.6.1 Narrative Description

Crib walls are a combination of wood, live branches, rock, and soil used to reconstruct eroded banks. They are used on outside bends to stabilize banks and can be used in areas where space is limited and vertical walls are necessary. The wood and cuttings of the crib wall provide aquatic habitat.

#### 2.6.2 Technique Information

- **Use:** Crib walls are used on outside bends to stabilize banks and can be used in areas where space is limited and vertical walls are necessary. Crib walls also provide natural habitat for riparian wildlife.
- **Other uses:** None.
- **Best applications:** On the outside of channel bends where severe bank erosion has occurred and other stream restoration methodologies, such as geomorphic channel design, can't be applied.
- **Computations:** A hydrologic and hydraulic analysis is required to evaluate depth and forces on the crib wall. Crib walls should be designed by a professional.
- **Key Features:** Logs, live branch cuttings, rock, soil, and steel reinforcing bars.
- **Cautions:**
  - Crib walls should not exceed 7 feet in height and 20 feet in length.
  - Upstream and downstream sections should be secured to the channel bank to prevent undercutting.

#### 2.6.3 Detail Drawings and Data Table

The following drawings and data table depict information that should be included in construction plans for submerged crib walls. The data table includes design guidelines and sources, where applicable.

## RIVER RESTORATION TOOLBOX PRACTICE GUIDE 6

Aquatic Habitat/Cover Feature Techniques  
April, 2018

**Table 6. Required Design Data for Submerged Crib Walls<sup>1</sup>**

Dimension <sup>2</sup>	Name	Typical Unit	Guidelines <sup>3</sup>	Description
A	Total Bank Height	Feet	Design input from a local geotechnical engineer should be obtained if the channel bank height exceeds 6 feet.	Total bank height that will be stabilized with the crib wall.
B	Bury Depth	Feet	Several methods for computing scour are widely available, such as those found in NRCS NEH Part 654, Technical Supplement 14B.	Bury depth should be consistent with expected scour conditions where the crib wall is placed.
C	Live stake diameter	Inches	1/2 – 2" (Iowa DNR 2006); ¾-3" (NRCS 2007a).	Diameter of prepared dormant live cutting from woody plant to be used as live stake – typically cite a permissible minimum and maximum diameter.
D	Live stake length	Feet	3' (Iowa DNR 2006); 3-10' (NRCS 2007a).	Length of prepared dormant live cutting from woody plant to be used as live stake. Length should be sufficient to reach low-flow water table elevation.
E	Log	Feet	12-18" Dia. X 24-30' long.	Structural log used in the construction of the crib wall.

1. Data are for submerged crib walls.
2. Some dimension labels are referenced in the detail drawings.
3. Common guidance, values, or ranges are given unless they require computation using site-specific input.

# RIVER RESTORATION TOOLBOX PRACTICE GUIDE 6

Aquatic Habitat/Cover Feature Techniques  
April, 2018

## Drawing 6. Submerged Crib Wall

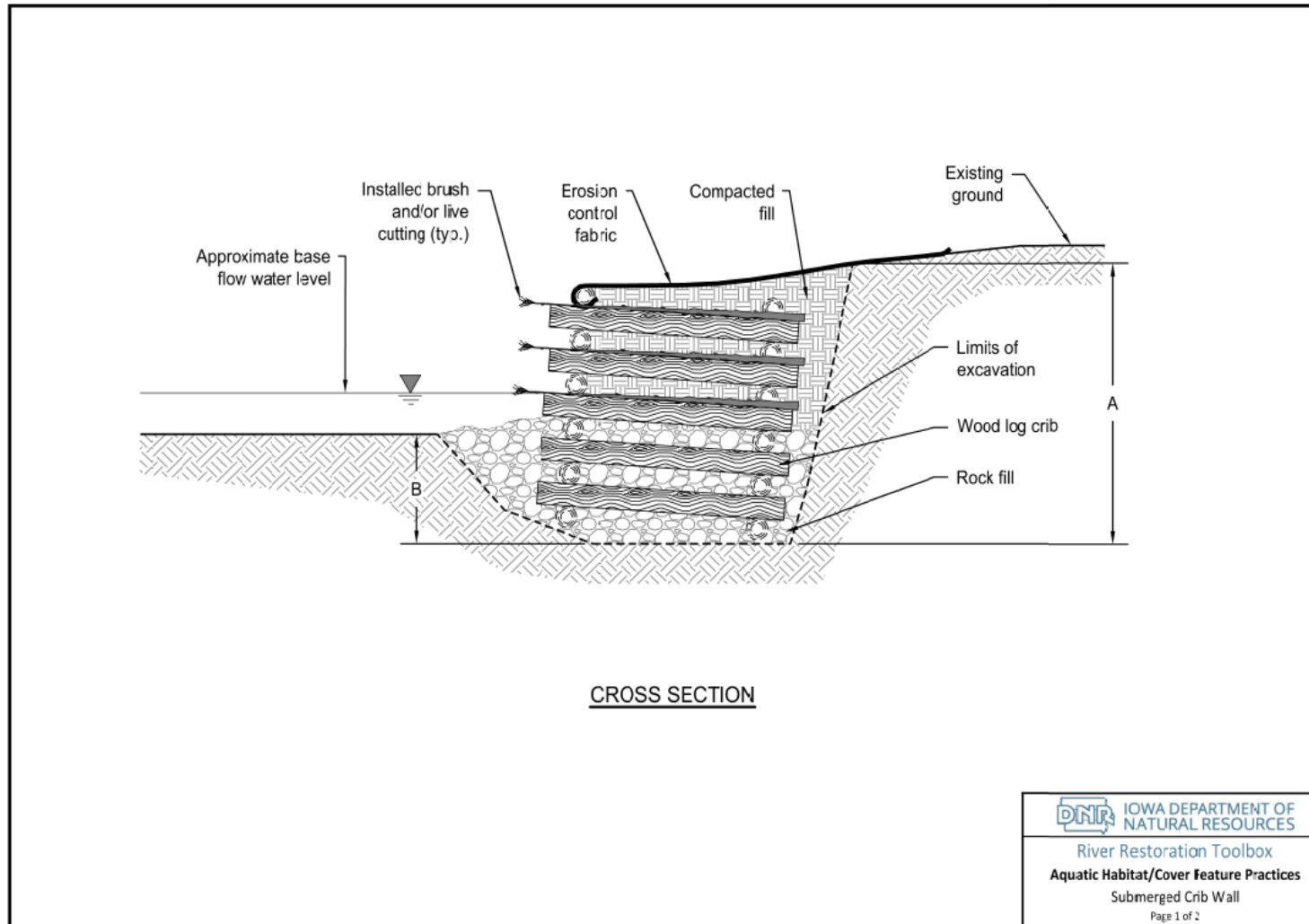

# RIVER RESTORATION TOOLBOX PRACTICE GUIDE 6

Aquatic Habitat/Cover Feature Techniques  
April, 2018

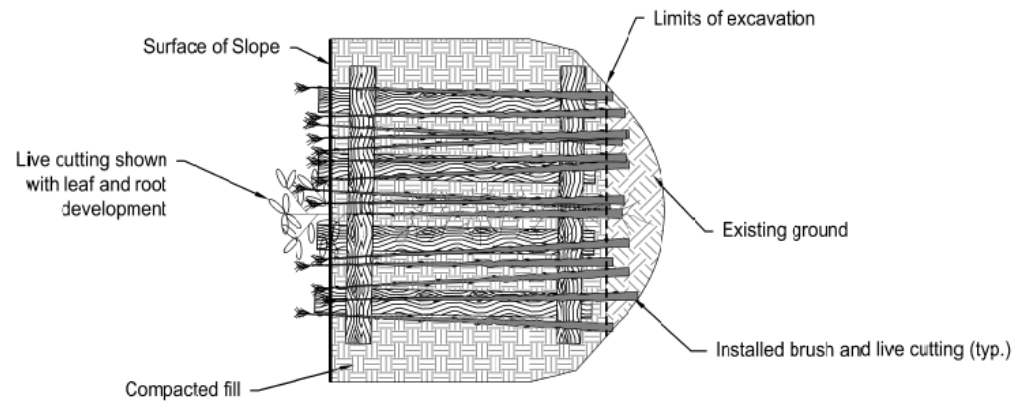

PLAN VIEW DETAIL

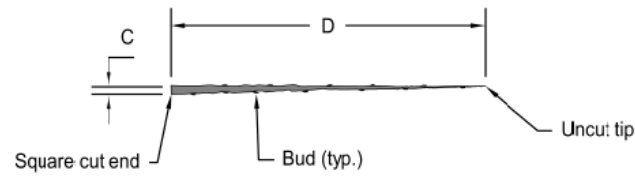

LIVE CUTTING DETAIL

**DNR** IOWA DEPARTMENT OF  
NATURAL RESOURCES

River Restoration Toolbox  
Aquatic Habitat/Cover Feature Practices  
Submerged Crib Wall

Page 2 of 2

Version 1.0 8/25/2017

## RIVER RESTORATION TOOLBOX PRACTICE GUIDE 6

Aquatic Habitat/Cover Feature Techniques  
April, 2018

### 2.6.4 Specifications

- Materials:
  - Logs
  - Live branch cuttings
  - Rock
  - Soil
  - Steel reinforcing bars
- Equipment/Tools: Excavator with a thumb attachment
- Sequence:
  - Excavate a trench
  - Place logs in alternating directions to form a box shape
  - Fasten logs together using rebar
  - Place rock fill in the bottom of the structure, up to the level of the streambed, and in front of the structure for added toe support.
  - Place live branch cuttings
  - Place soil on top of branches
- Workmanship: Structure toe should be placed coincident with the low flow channel.
- Maintenance: A scheduled monitoring and maintenance program is recommended in order to remove debris and or sediment that has accumulated in or near the structure, and to also ensure the unexpected scour conditions have not developed.



## RIVER RESTORATION TOOLBOX PRACTICE GUIDE 6

Aquatic Habitat/Cover Feature Techniques  
April, 2018

### 2.6.5 Photographs



**Photo 10.** Submerged Cribwall. Source: Unknown.



**Photo 4.** Submerged Crib Wall. Source: Unknown.

## RIVER RESTORATION TOOLBOX PRACTICE GUIDE 6

References  
April 1, 2018

### 3.0 REFERENCES

Derrick, D. 2013. Locked Logs Power Point presentation.

Fischenich, C. and R. Seal. 2000. Boulder Clusters. EMRRP Technical Notes Collection (ERDC TN-EMRRP-SR-11), U.S. Army Engineer Research and Development Center, Vicksburg, MS.  
[www.wes.army.mil/el/emrrp](http://www.wes.army.mil/el/emrrp).

Illinois State Water Survey. 1992. Value of Instream Habitat Structures to Smallmouth Bass. SWS Miscellaneous Publication 139. Champaign, Illinois.

Rosgen, D. 1996. Applied River Morphology. Wildland Hydrology. Pagosa Springs, Colorado.

Vetrano, D.M., 1988. Unit Construction of Trout Habitat Improvement Structures for Wisconsin Coulee Streams. Administrative Report No. 27. Bureau of Fisheries Management Department of Natural Resources, Madison, Wisconsin.

White, W., J. Beardsley, and S. Tomkins. 2011. Waukegan River Illinois National Nonpoint Source Monitoring Program Project. Illinois State Water Survey Institute of Natural Resource Sustainability, University of Illinois at Urbana-Champaign, Champaign, Illinois.

White, R.J. and O.M. Brynildson. Guidelines for Management of Trout Stream Habitat in Wisconsin. Technical Bulletin No. 39. Wisconsin Department of Natural Resources. Madison, Wisconsin.